

# COMPACT

SMALL & STRONG LIFTER FOR HANDLING REELS

## THE SMALLEST BATTERY-DRIVEN LIFTER

Compact is the market's smallest battery-driven lifter for handling reels. The lifter comes with a combined boom and V-block. The boom is equipped with a wheel which ensures that the reel can easily be pushed onto the machine. The V-block is turnable and can be used for either a side or through-going shaft.

The lifting equipment can be fitted in various heights according to the task. The boom handles reels up to 100 kg and the V-block has a capacity of 60 kg.

Compact comes with an automatic overload switch, and all movable and electrical parts are shielded. The lifting and lowering function is controlled with a push button.

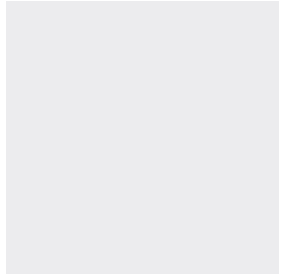

# COMPACT

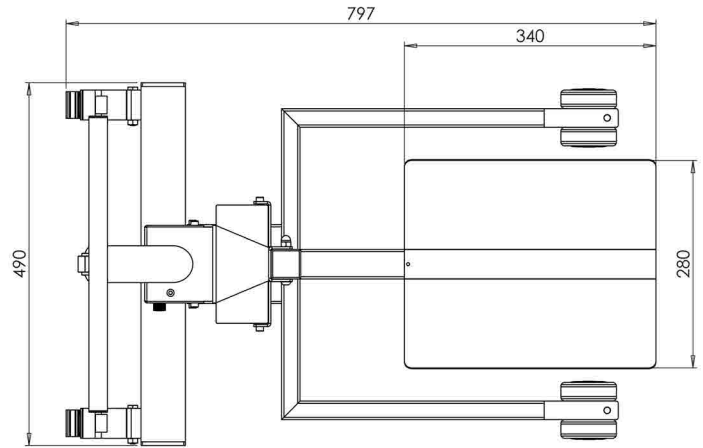
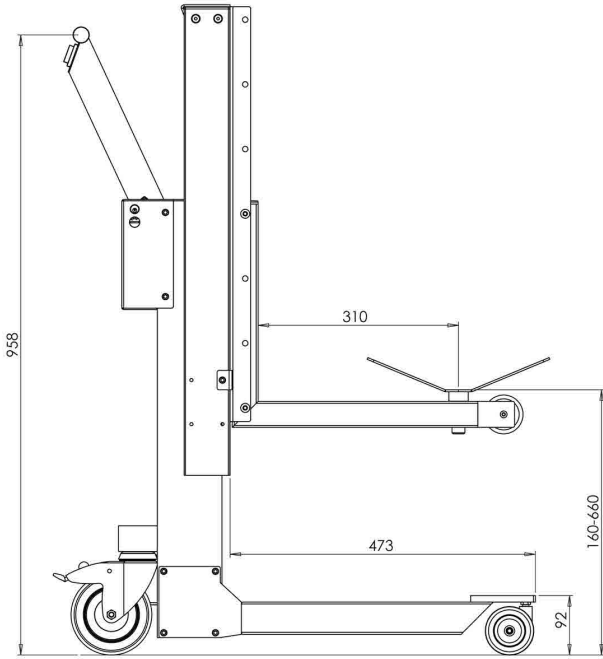

Capacity	Lifting height	Height	Speed	Batteries	Weight
kg	mm	mm	mm/sec	Voltage / AH	kg
100/60	825/1325	958	95	24/1,2	24

## WHEELS

Front wheels, swivel Ø75 mm  
Rear wheels, swivel Ø125 mm with brake

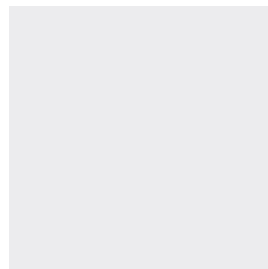

**SEE VIDEOS:  
WWW.YOUTUBE.COM/HOVMANDIMPACT**

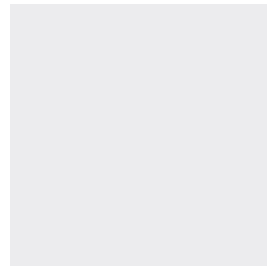

# HOVMAND

LIFTING & MOVING TECHNOLOGY

HOVMAND A/S • SANDVADSVEJ 15 A • DK-4600 KØGE  
HOVMAND GMBH • RUPERT-MAYER-STR. 44 • DE-81379 MÜNCHEN  
PHONE +45 57 83 33 00 • CUSTOMERSERVICE@HOVMAND.COM •  
WWW.HOVMAND.COM