

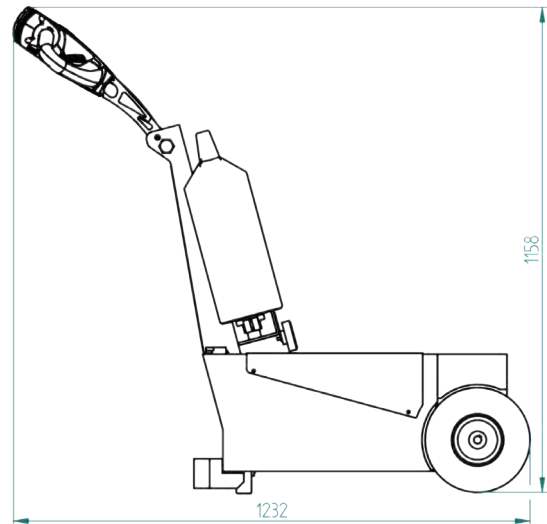

Specifications T1500-D

Frame	Steel, powder coated
Drive	24V DC, 600W, 100 rpm
Weight	180 kg
Weight trailer	1500 kg
Battery	Exchangable batterypack
Speed	Max. 4,7 km/h
Drive wheels	Full rubber ø250x80 mm
Width	486mm
Length	1232mm
Adze height	750-1158mm
Folded	770mm
Noise level	68,5 dB
To use from	-40 °C / 70 °C
Protection class	Machine IP44

Dimensions T1500-D

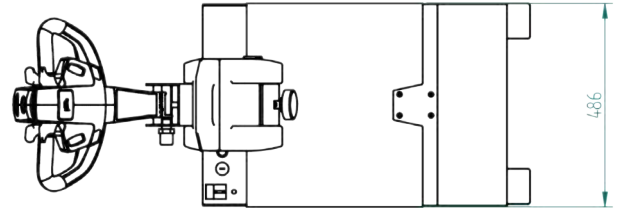

Pulling power T1500-D (in kg)

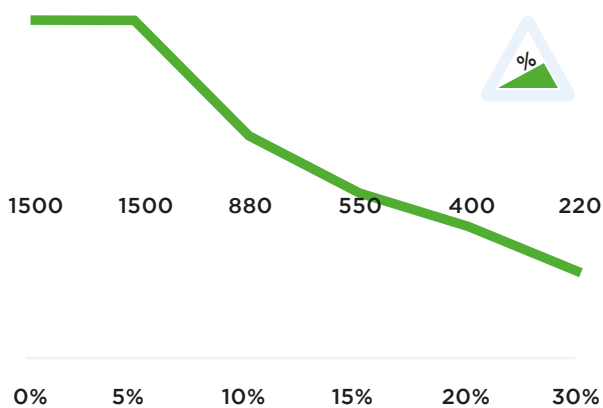

*Measured with a trolley with 2 swivelwheels and 2 fixed castors. Wheel diameter: 160mm

Standard T1500-D



Standard parts T1500-D

Charger 24V 5A incl. charging cable



Item number:
OPT0009

Accu maintenance-free AGM 24V-20Ah, 6018



Item number:
OPT0110-RAL6018

Full-rubber drive wheel, black



Item number:
M0248

Adjustable tillerhead



Item number:
Standardpart 1

Safety switch



Item number:
Standardpart 2

2 programmable speeds



Item number:
Standardpart 3

Standard parts T1500-D

**Engine 600W
100RPM BRAKE
6911413X**



Item number:
M2098

**LED battery indicator
LBF318-24V**



Item number:
M0123

Options T1500-D



Battery Lithium-Li-FePO4 25,6V-36Ah GREEN

Article number:
OPT0106



Battery Lith. instead Battery AGM GREEN

Including charger

Article number:
OPT0107



Accu maintenance-free AGM 24V-20Ah, 6018

Article number:
OPT0110-RAL6018



SURCH driving wheel airtire nonmark GREY

SURCHARGE driving wheel airtire non-marking GREY

Article number:
OPT0156



SURCH drive wheel airtire foamed 2b BLAC

Article number:
OPT0158



SURCH driving wheel full rubber nm GREY

Article number:
OPT0161



SURCHARGE driving wheel non-marking YELL

Article number:
OPT0163



Horn 90dB

Article number:
OPT0045



Horn

Article number:
OPT0055



Horn 103 dB

Article number:
OPT0059



Emergency stop complete

Article number:
OPT0063



Strobelight cast iron tiller head

Article number:
OPT0076

Options T1500-D



**Strobelight on pole
T1000-D/T1500-D**

Article number:
OPT0124

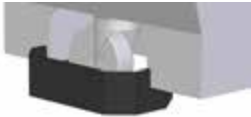

**Cover for caster
T1500-D**

Article number:
OPT0130



**Safety Fender for
T1500-D**

Article number:
OPT0167



**Bellybutton 2-step
reset**

*After bellybutton use off/
on switch is necessary*

Article number:
OPT0168



**Acoustic signal while
driving**

Article number:
OPT0253



**Acoustic signal dri-
ving backwards**

Article number:
OPT0254



**On/off switch machi-
ne**

Article number:
OPT0016



Remote

8-channel

Article number:
OPT0024-5



Radio remote

6-channel

Article number:
OPT0026-5



Push Bar

Article number:
OPT0048



**hour counter com-
plete**

Article number:
OPT0056



Antistatic strip

Article number:
OPT0058

Options T1500-D

Code lock



Article number:
OPT0068

Document holder



Article number:
OPT0127

Preparation electric hook



Article number:
OPT0143

Ignition key unequal key



Article number:
OPT0145

Ignition key equal key



Article number:
OPT0146

Ignition key under larger tiller head



*Unequal key. Only with
OPT0171*

Article number:
OPT0147

Ignition key under larger tiller head



*Equal key. Only with
OPT0171*

Article number:
OPT0148

Tillerhead limitation



Article number:
OPT0169

Customized programming



Article number:
OPT0170

Larger Tiller-Head



With 6 switch positions

Article number:
OPT0171

Maximum weight



Article number:
OPT0172

Programmer for Ital-sea



Article number:
D0003

Options T1500-D



Charger unit for 1 AGM battery

Article number:
OPT0015



Charging Station for 1 Lithium battery

Article number:
OPT0023



Charging station for 5 Lithium batteries

Article number:
OPT0029



Charging station for 5 batteries

Article number:
OPT0039



U-Frame for waste container 1000/1100L

Article number:
OPT0088



Charging Station for 6 AGM Batteries

Article number:
OPT0115



Adaptor for 2 wheel bin's

Article number:
OPT0151



Locking module charging Station 6 units

Locking module charging Station with 6 units

Article number:
OPT0152



Surcharge single charging station

Article number:
OPT0261



Folding Hook, diameter 16

Article number:
H0128-D16



Folding Hook, diameter 20

Article number:
H0128-D20



Folding Hook, diameter 25

Article number:
H0128-D25

Options T1500-D



Folding Hook, diameter 32

Article number:
H0128-D32



Folding Hook, diameter 35

Article number:
H0128-D35



Basic hook

Article number:
H7070



Basic hook High

Article number:
H7080



Hook Straightener

Article number:
OPT0012



Electric lifting module for Hooks

Article number:
OPT0050



Folding hook for flower trolleys

Article number:
OPT0099

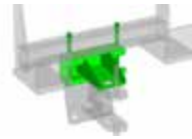

Support for exchangeable hook

Article number:
OPT0122



Electrical locking module for hook

Article number:
OPT0129



Automatic trailer coupling

Article number:
OPT0200



Basemodule, spring, bolt en counterplate

Article number:
OPT0203



Jacket Movexx size M

Article number:
OPT0197

Options T1500-D

Jacket Movexx size L



Article number:
OPT0198

Jacket Movexx size
XL



Article number:
OPT0199

Movexx Parking label



Article number:
OPT0245

Sticker Movexx Inside



Article number:
OPT0247



Movexx International B.V.

Wiltonstraat 61-63

3905 KW Veenendaal

Tel +31 (0)318 51.99.00

Fax +31 (0)318 50.80.20

E-mail info@movexx.nl