

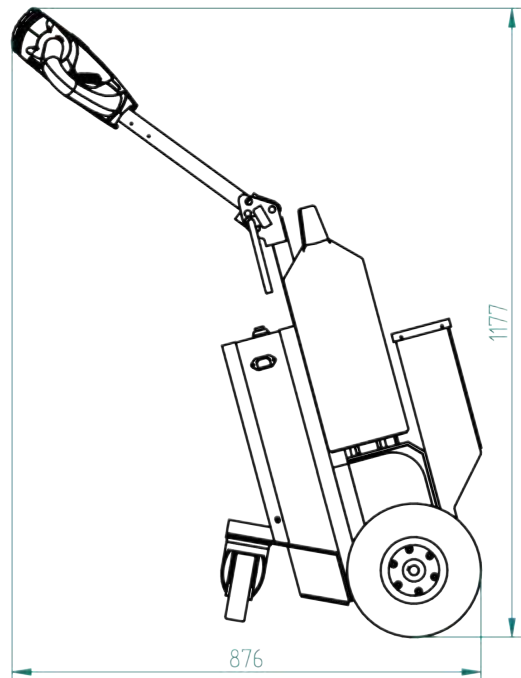

Specifications T1500

Frame	Steel, powder coated
Drive	24V DC, 600W, 100 rpm
Weight	105 kg
Weight trailer	1500 kg
Battery	Exchangable batterypack
Speed	Max. 4,7 km/h
Drive wheels	Full rubber ø250x80 mm
Width	483mm
Length	876mm
Adze height	750-1177mm (variable)
Folded	770mm
Noise level	68,5 dB
To use from	-40 °C / 70 °C
Protection class	Machine IP44

Dimensions T1500

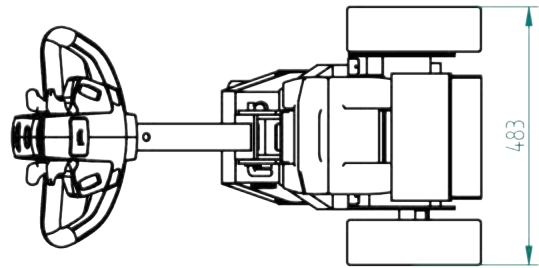

Pulling power T1500 (in kg)

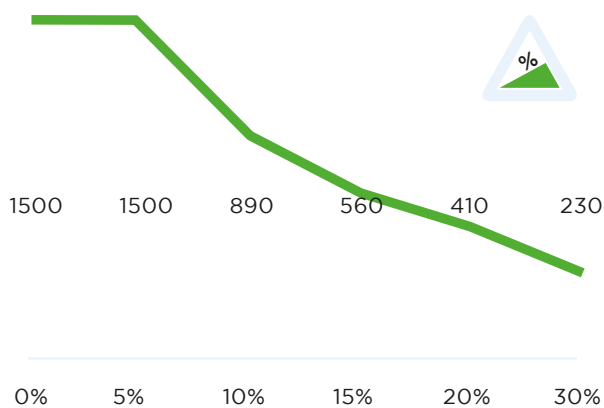

*Measured with a trolley with 2 swivelwheels and 2 fixed castors. Wheel diameter: 160mm

Standard T1500



Standard parts T1500

Charger 24V 5A incl. charging cable



Item number:
OPT0009

Accu maintenance-free AGM 24V-20Ah, 6018



Item number:
OPT0110-RAL6018

Full-rubber drive wheel, black



Item number:
M0248

Adjustable tillerhead



Item number:
Standardpart 1

Safety switch



Item number:
Standardpart 2

2 programmable speeds



Item number:
Standardpart 3

Standard parts T1500

Engine 600W 100RPM BRAKE 6911413X



Item number:
M2098

LED battery indicator LBF318-24V



Item number:
M0123

Options T1500



Extra plug to recharge the battery

Article number:
OPT0001



Battery Lithium-Li-FePO4 25,6V-36Ah GREEN

Article number:
OPT0106



Battery Lith. instead Battery AGM GREEN

Including charger

Article number:
OPT0107



Accu maintenance-free AGM 24V-20Ah, 6018

Article number:
OPT0110-RAL6018



SURCH driving wheel airtire nonmark GREY

SURCHARGE driving wheel airtire non-marking GREY

Article number:
OPT0156



SURCH drive wheel airtire foamed 2b BLAC

Article number:
OPT0158



SURCH driving wheel full rubber nm GREY

Article number:
OPT0161



SURCHARGE driving wheel non-marking YELL

Article number:
OPT0163



Surcharge Drive wheel Ø300 Rubber Nonm.

Article number:
OPT0256



Horn with controll on bellybutton

Article number:
OPT0049



Horn 103 dB

Article number:
OPT0059



Emergency stop complete

Article number:
OPT0063

Options T1500

Strobelight



Article number:
OPT0065

Bellybutton 2-step reset



After bellybutton use off/on switch is necessary

Article number:
OPT0168

Acoustic signal while driving



Article number:
OPT0253

Acoustic signal driving backwards



Article number:
OPT0254

Remote



8-channel

Article number:
OPT0024-4

Radio remote control



6 channel

Article number:
OPT0026-4

Push Bar



Article number:
OPT0048

Document holder with clip



Article number:
OPT0053

hour counter complete



Article number:
OPT0056

Horn 90dB



Article number:
OPT0057

Antistatic strip



Article number:
OPT0058

Code lock



Article number:
OPT0068

Options T1500



Preparation electric hook

Article number:
OPT0143



Ignition key unequal key

Article number:
OPT0145



Ignition key equal key

Article number:
OPT0146



Ignition key under larger tiller head

*Unequal key. Only with
OPT0171*

Article number:
OPT0147



Ignition key under larger tiller head

*Equal key. Only with
OPT0171*

Article number:
OPT0148



Customized programming

Article number:
OPT0170



Larger Tiller-Head

With 6 switch positions

Article number:
OPT0171



Programmer for Ital-sea

Article number:
D0003



Charger unit for 1 AGM battery

Article number:
OPT0015



Charging Station for 1 Lithium battery

Article number:
OPT0023



Charging station for 5 Lithium batteries

Article number:
OPT0029



Charging station for 5 batteries

Article number:
OPT0039

Options T1500



Frame for 4-wheel waste container

Article number:
OPT0085



U-Frame for waste container 1000/1100L

Article number:
OPT0088



Charging Station for 6 AGM Batteries

Article number:
OPT0115



Locking module charging Station 6 units

Locking module charging Station with 6 units

Article number:
OPT0152



Surcharge single charging station

Article number:
OPT0261



Basic hook 15° lowered

Article number:
H7050



Basic hook High

Article number:
H7060



Hook Straightener

Article number:
OPT0012



Electric lifting module for Hooks

Article number:
OPT0050

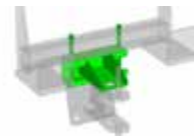

Support for interchangeable hook

Article number:
OPT0122



Electrical locking module for hook

Article number:
OPT0129



Handle bar locking module

Voor machines met een disselkopsteun uit vierkante buis

Article number:
OPT0189

Options T1500



**Basemodule, spring,
bolt en counterplate**

Article number:
OPT0202



**Locking Module ma-
nual**

Article number:
OPT0220



Jacket Movexx size M

Article number:
OPT0197



Jacket Movexx size L

Article number:
OPT0198



**Jacket Movexx size
XL**

Article number:
OPT0199



Movexx Parking label

Article number:
OPT0245



Sticker Movexx Inside

Article number:
OPT0247



Movexx International B.V.

Wiltonstraat 61-63

3905 KW Veenendaal

Tel +31 (0)318 51.99.00

Fax +31 (0)318 50.80.20

E-mail info@movexx.nl